



Ice Cream Freezer

IC352D



| | | | |
|-------------|-------------------|------------------|------------|
| Item number | 23424310000IC352D | Taric goods code | 8418501190 |
| EAN code | 5704704019546 | QTY in 40HQ | 81 |

Short Description

Key features

- Curved sliding glass lids with lock
- 5 strong wire baskets including 2 dividers in each
- Coated white steel inner liner
- 4 strong castors
- Suitable for branding

Measurement Drawings

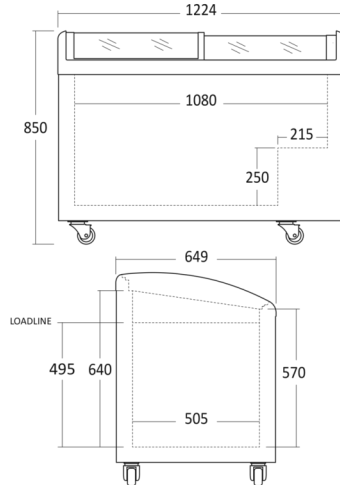

Dimensions and weight

| | |
|---------------------------------------|------------------|
| Product dimensions, HxWxD, mm | 850 x 1224 x 649 |
| Product depth w/handle, mm | 649 |
| Packaging dimensions, HxWxD, mm | 895 x 1310 x 735 |
| Total packaging volume m ³ | 0,862 |
| Gross volume, L | 330 |
| Net volume, L | 251 |
| Gross- / Net volume, L | 330 / 251 |
| Internal dimensions, HxWxD, mm | 640 x 1080 x 505 |
| Gross- / Net weight, kg | 79 / 68 |

Performance and consumption

| | |
|------------------------------------|------------|
| Energy efficiency class | D |
| Daily Energy Consumption, kWh/24 | 1,86 |
| Annual energy cons. kWh/a | 680 |
| Energy Efficiency Index (EEI) | 41,54 |
| Noise level, dB(A) | 70 |
| Refrigeration / freezing technique | Static |
| Climate class | 7 |
| Temperature class | C1 |
| Type of refrigerant / gas gr. | R290a / 80 |
| Temperature range °C | -18 / -24 |

Installation and power

| | |
|-------------------------|-----------|
| Voltage / hertz, V/hz | 230 / 50 |
| Peak power watt, W | 280 |
| Watt / Ampere, W/A | 180 / 2.2 |
| Length of Powercord, cm | 200 |

Design and comfort

| | |
|------------------------|-----------------------|
| Controller | Mechanical |
| Control panel | Outside |
| Digital display | No |
| Internal light | No light |
| External thermometer | Yes |
| Door- / lid type | Sliding |
| Handle | Integrated |
| Number of castors, pcs | 4 castors (2 w/brake) |
| Lock & Key | Yes |

Colour and material

| | |
|---------------------------------|---------------|
| Outside colour | White |
| Inside Colour | White |
| Colour and material of door/lid | Sliding glass |

Features

| | |
|----------------------------------|-----|
| Number of baskets, pcs | 5 |
| Basket Size (HxWxD) (mm) | Yes |
| Max loading per shelf/basket, kg | 20 |

scandomestic

Scandomestic A/S . Linåvej 20 . DK-8600 Silkeborg . Tel.: +45 7242 5571 . www.scandomestic.dk